

APPLY LUBRICANT TO ALL SEALS
PRIOR TO INSTALLATION.
DO NOT USE SILICONE TYPE LUBRICANTS.
FOR PROPER ARM MOUNTING SEE IS1505.

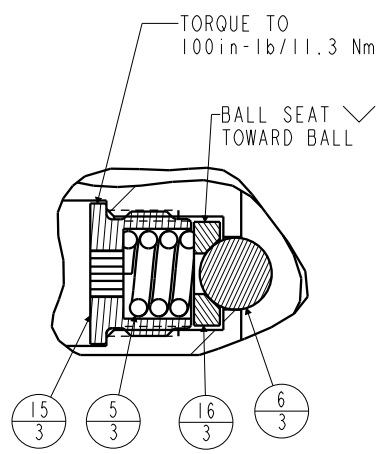

DETAIL A
SCALE 1.500

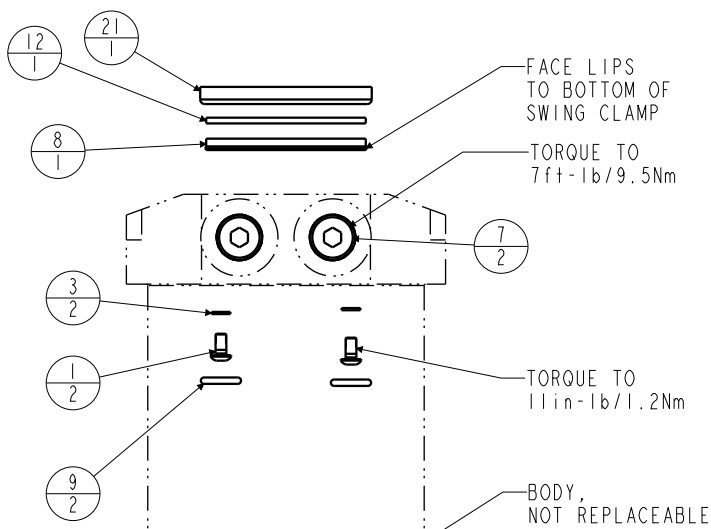
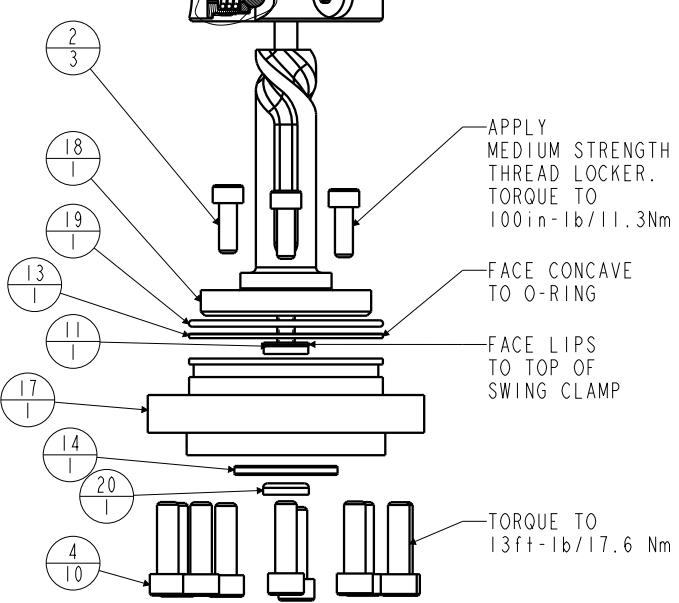
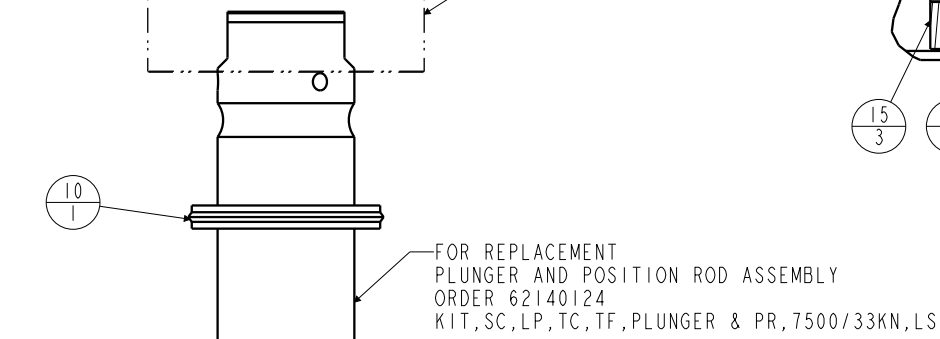

No.	QTY	PART No.	DESCRIPTION	Std Seal Kit	FKM Seal Kit
N/A	N/A	IS1505	INSTRUCTION SHEET, ARM INSTALLATION		
N/A	N/A	6V711054	SEAL KIT, FKM		
N/A	N/A	60711054	SEAL KIT, STANDARD		
21	1	39V11051	WIPER, PRESS-IN, (1-1/2)	X	X
20	1	39V10029	WIPER, PRESS-IN, (1/4)	X	X
19	1	39H51002	O-RING, (-033)	X	39V51002
18	1	81592137	CAM, SC, LP, 7500/33KN, LH, LS, TC, PR		
17	1	81532115	CAP, END, SC, LP, 33KN/7500, PR		
16	3	81532108	SEAT, BALL, SC, LP, TC		
15	3	81532107	RETAINER, SC, LP, TC		
14	1	81500040	RING, LOCATOR, SC, LP, PR		
13	1	39054017	BU RING, (-033)	X	39054023
12	1	39054016	BU RING, (1.5x.125x.063)	X	X
11	1	39052043	SEAL, LL, (1/4 X 1/8 X 1/8 X 1/2)	X	39V52043
10	1	39052030	SEAL, CROWN, 1-3/4x2-1/8x1/4	X	39V52030
9	2	39050042	O-RING, (-011)	X	39051025
8	1	39011075	SEAL, LL, (1-1/2 X 1/8 X 1/8 1-3/4)	X	39V11075
7	2	30601144	PLUG, SOCH, SAE 4		
6	3	23650004	BALL, TUNGSTEN-CARBIDE. 250		
5	3	23350066	SPRING, COMPRESSION		
4	10	21500304	SHCS, M6 X 1.0-6G X 20MM		
3	2	21500200	WASHER		
2	3	21500031	SHCS, M5 X 0.8 X 14, ALY		
1	2	21500019	SCREW, CAP, BTNH, M3 X 6, ALY		

PARTS LIST

ASSEMBLIES AFFECTED
14062104PR
14062104FPR

VEKTEK, INC.
1334 E. SIXTH AVE. P.O. BOX 625
EMPORIA, KS. 66801 U.S.A.

SIZE A	PL7205	REV C
-----------	--------	----------

C	5762	RELEASE	JDW	07/15/25
REV	IN ACCORDANCE WITH ECN	EFFECTIVE DATE	REVISED BY	DATE
DRW BY:	DATE: 10/16/13	DRAWING STATUS: Released		
PRODUCTION APPROVED FOR RELEASED STATUS ONLY				

